

1 2 3 4 5 6 7 8

A A

B B

C C

D D

E E

F F

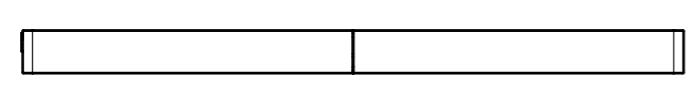

VIEW B
SCALE 1:5

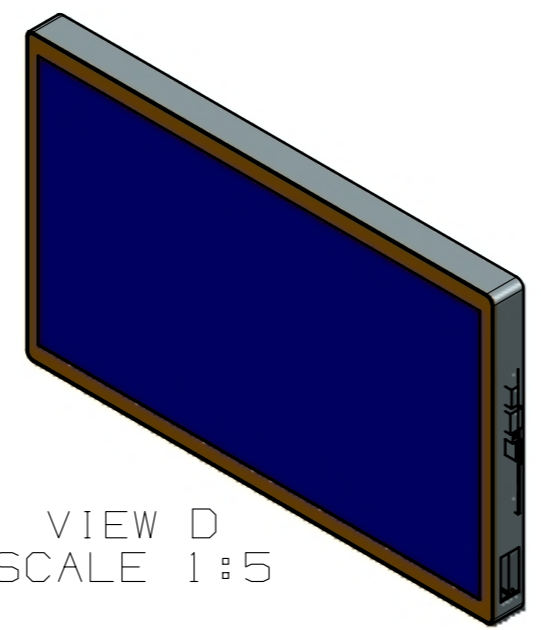

VIEW D
SCALE 1:5

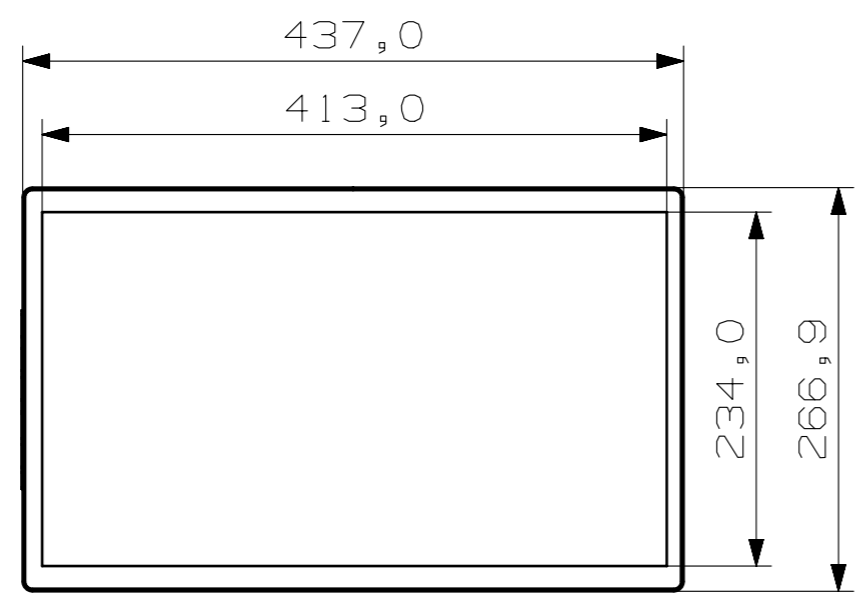

VIEW A
SCALE 1:5

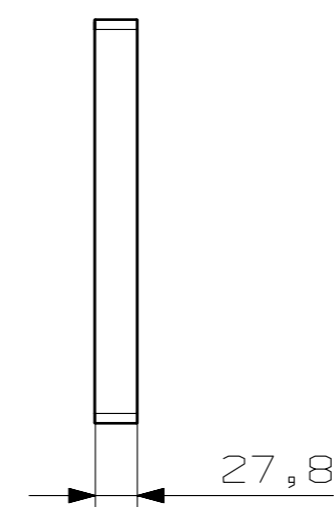

VIEW C
SCALE 1:5

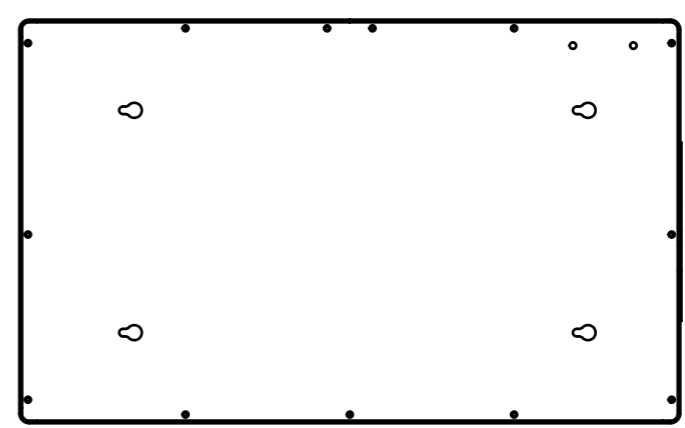

制程跟踪卡			
工序名称	数量	责任人	日期
下料			
折弯			
焊接			
表面处理			
包装			

- 技术要求
1. 一般线性公差按GB 1804 - M级
 2. 不允许有划伤、碰伤等表面缺陷
 3. 去锐边锐角，去油污
 4. 未标折弯内为R0.5
 5. 未标折弯角度为90° ± 0.5°
 6. 虚线区域为更改/增加结构

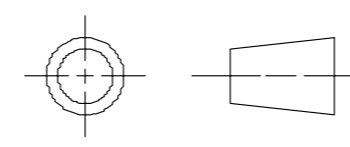

ALL DIMENSIONS IN MM

FIRST ISSUED		TITLE		
DRAWN BY				
CHECKED BY				
APPROVED BY		SIZE	DWG NO.	SHEET REV
		A3	185-andrid-20190524	A
		SCALE 1:1	SHEET 1 OF 4	

1 2 3 4 5 6 7 A3